DIY Course Authoring: Best Practices and Tips for Small Content Creation Teams

**Julie Mullen, Lauren Milechin
and Jason Williams**

Open edX Conference

15 June 2016



This material is based upon work supported by the Assistant Secretary of Defense for Research and Engineering under Air Force Contract No. FA8721-05-C-0002 and/or FA8702-15-D-0001. Any opinions, findings, conclusions or recommendations expressed in this material are those of the author(s) and do not necessarily reflect the views of the Assistant Secretary of Defense for Research and Engineering.

Delivered to the US Government with Unlimited Rights, as defined in DFARS Part 252.227-7013 or 7014 (Feb 2014). Notwithstanding any copyright notice, U.S. Government rights in this work are defined by DFARS 252.227-7013 or DFARS 252.227-7014 as detailed above. Use of this work other than as specifically authorized by the U.S. Government may violate any copyrights that exist in this work. © 2016 Massachusetts Institute of Technology.



Goal

**To create effective online
and blended learning environments.**



Outline



- **Introduction**
- **Instructional Design Overview**
- **Preparation**
- **Capturing**
- **Editing**
- **Delivery**
- **Summary**



Starting Point



Traditional Classrooms

Benefits:

- Social Learning
- Personal relationship with Teacher
- Easily adapted to students needs
- Interactive



Workshops*

Benefits:

- Intense, focus on single topic
- Mastery of specific skill
- Interactive
- Social learning



Tutors

Benefits:

- Individualized responses to questions
- Individualized presentation of material
- Interactive



Online & Blended Learning

The screenshot displays a learning management system interface. At the top is a navigation bar with icons for back, home, search, and other functions. Below the navigation bar, there are several content panels:

- Code Panel:** A panel showing R code for matrix operations and a resulting matrix. The code includes `ALM = L * A`, `ALMthresh = ALM - threshVal`, and `ALMthresh > 0`. The matrix has columns 1 through 14 and 15 through 23. Red circles highlight specific elements in the matrix.
- Tables, Tablets, and Tablet Servers Panel:** A panel with three sub-tables: "Table", "Tablets", and "Tablet Servers". Each sub-table contains data for rows (rowA through rowH) and columns (col1 through col5). Arrows indicate relationships between the data in these tables.
- Video Player:** A video player showing a man in a red shirt speaking.
- Question Panel:** A panel with two questions. Question 4 asks "Does the correlation matrix need to be thresholded?" with a "FINAL CHECK" button and a submission count of 0/1. Question 5 asks "You can get the number of words pairs of users have in common by performing another multiplication using the matrix you have already constructed. What should the inner dimension be?" with radio buttons for "Users" and "Words", and a "FINAL CHECK" button with a submission count of 0/1.
- Text Panel:** A panel with text explaining the goal of understanding Twitter user behavior. It lists questions: "what locations users commonly Tweet from (downs, cities, GPS Coordinates)", "what words are commonly used by users", and "what words are common to different community locations". It also describes the data source and the goal of correlating users, locations, and words.

- **Benefits:**
 - Interleaved content and questions to develop mastery
 - Lectures become “Learning modules”
 - Learn at your own pace



Process for Workshop Conversion From Face-to-Face to Online

Part 1: Agenda

- Introduction
- Systems Engineering
- Databases and Accumulo
- Cloud Computing

Day 1

- Roughly broken into 3 parts:
 - Part 1: Introduction to Big Data and Cloud Computing
 - Part 2: Database Technologies
 - Part 3: Introduction to Apache Accumulo
- Hands-on-exercises in Day 2 will reinforce the concepts taught

Course Goal:
To give you the knowledge needed to effectively use Apache Accumulo and knowledge about other Hadoop technologies.

TODAY'S AGENDA

- 0900-1030 Accumulo technical overview
- 1030-1100 Intro to Python & exercises
- 1100-1300 Exercise setup & lunch

GOALS OF OVERVIEW

- Understand Accumulo design goals & fundamentals
- Introduction to using Accumulo
 - Data model
 - Client API
 - Indexing strategies

Agenda

- SciDB Install and Configuration
- Data Load
- Array Data Model and Redimension

Plan for Today

- Learning:
 - SciDB configuration
 - Data model and query language
 - Example computations
 - SciDB-UDF
- Datasets:
 - NASA Moods
 - From <http://hdsr.jpl.nasa.gov/>
 - MOODBASE
 - POF California
 - From USGS

Initial Material



The Data Challenge

- Challenge Overview
 - ✓ Volume
 - ✓ Velocity
 - ✓ Veracity
 - ✓ Variety
 - ✓ Challenge Review

Review existing material, develop concept Map



Database Fund. ??

Database Arch.

Data Definitions

Sort existing material into concepts, identify gaps



Database Fund. ??

In Practice

In Depth

Create new material and update existing material



Database Fundamentals

Collection of data and supporting data structures

- SQL Database
- Database user and schema
- Database query
- DB administration: user security and permissions

What's the right NoSQL database to use?

This is a tough question. There are tons of technologies out there that seemingly have the same qualities. Generally, if you're looking for high performance use of the common NoSQL use cases of the Big Data world, you're right: NoSQL.

At the end of the day, it's usually very important to take a look at the end-to-end pipeline and make sure that the technology you use doesn't

Challenge of Data Velocity

Data Generated Per Minute

- Facebook: 364.476 pieces of content
- Twitter: 100,000 tweets
- YouTube: 48 hours of new video
- Google: 2,000,000 new queries
- Internet Population: 3.1 Billion people

NEWSQL DATABASES (1 sort position)

Which of the following is a NoSQL database?

- MySQL
- Apache Accumulo
- MySQL
- None of the above

Create Courseware



Process for Workshop Conversion From Face-to-Face to Online

Part 1: Agenda

- Introduction
- Systems Engineering
- Databases and Accumulo
- Cloud Computing

Day 1

- Roughly broken into 3 parts:
 - Part 1: Introduction to Big Data and Cloud Computing
 - Part 2: Database Technologies
 - Part 3: Introduction to Apache Accumulo
- Hands-on-exercises in Day 2 will reinforce the concepts taught

Course Goal:
To give you the knowledge needed to effectively use Apache Accumulo and knowledge about other DB technologies.

TODAY'S AGENDA

- 0900-1030 Accumulo technical overview
- 1030-1100 Intro to Python & exercises
- 1100-1300 Exercise setup & lunch

GOALS OF OVERVIEW

- Understand Accumulo design goals & fundamentals
- Introduction to using Accumulo
 - Data model
 - Client API
 - Indexing strategies

Agenda

- SciDB Install and Configuration
- Data Load
- Array Data Model and Redimension

Plan for Today

- Learning:
 - SciDB configuration
 - Data model and query language
 - Example computations
 - SciDB, LAD
- Datasets:
 - NASA Moods
 - From <http://data.sci.nasa.gov/>
 - MOODBASE
 - POF California
 - From USGS

Initial Material

The Data Challenge

- Challenge Overview
 - ✓ Volume
 - ✓ Velocity
 - ✓ Veracity
 - ✓ Variety
 - ✓ Challenge Review

Review existing material, develop concept Map

Database Fund. ??

Database Arch.

Data Definitions

Sort existing material into concepts, identify gaps

Database Fund. ??

In Practice

In Depth

Create new material and update existing material

Database Fundamentals

What's the right NoSQL database to use?

Challenge of Data Velocity

2011 Data Generated Per Minute

- Facebook: 86.476 pieces of content
- Twitter: 100,000 tweets
- YouTube: 48 hours of new video
- Google: 2,000,000 new queries
- Internet Population: 3.1 Billion people

NEWSQL DATABASES (100 results)

Which of the following is a NoSQL database?

- MySQL
- Apache Accumulo
- MySQL
- None of the above

Create Courseware



Course Authoring Roles

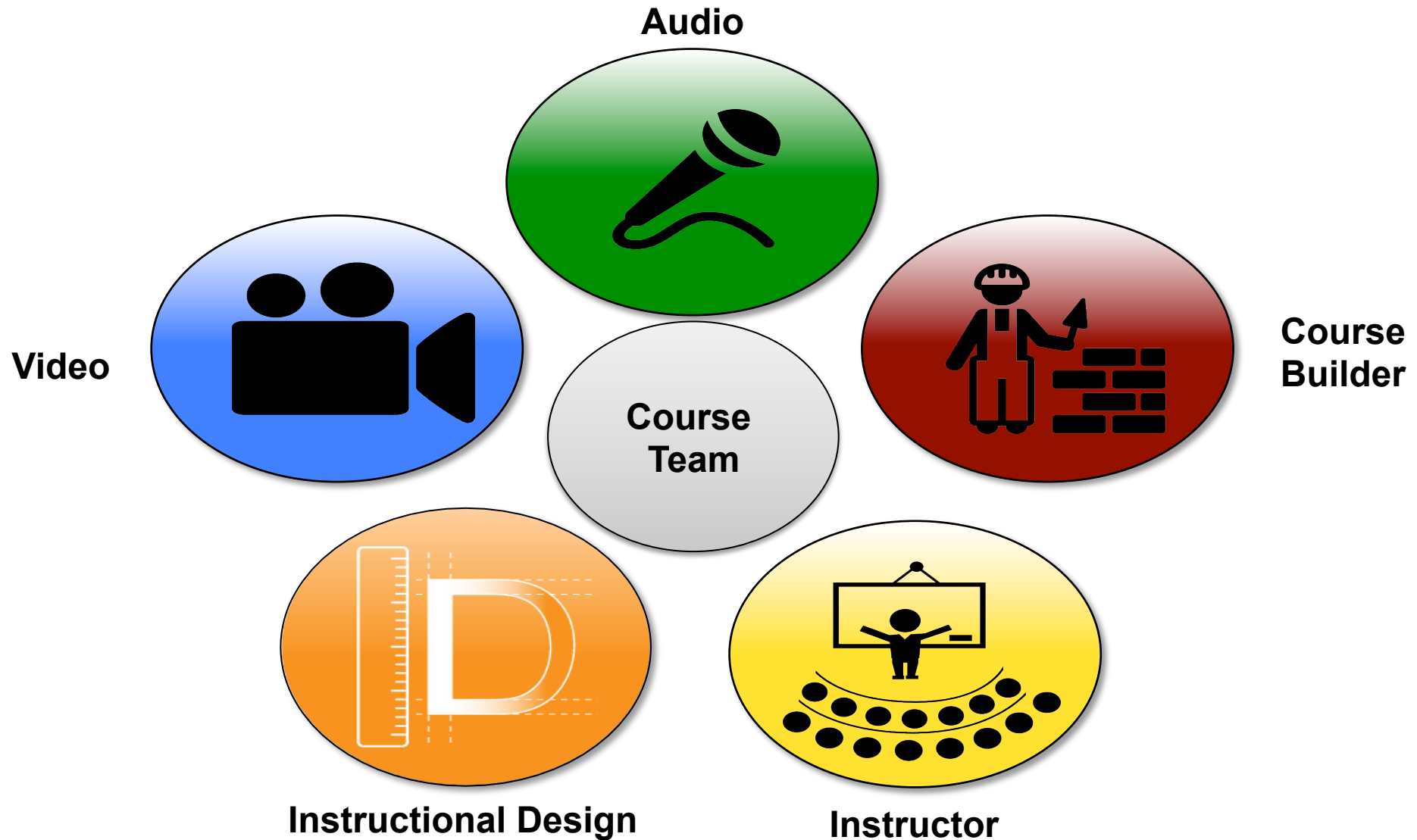



Course Authoring Roles

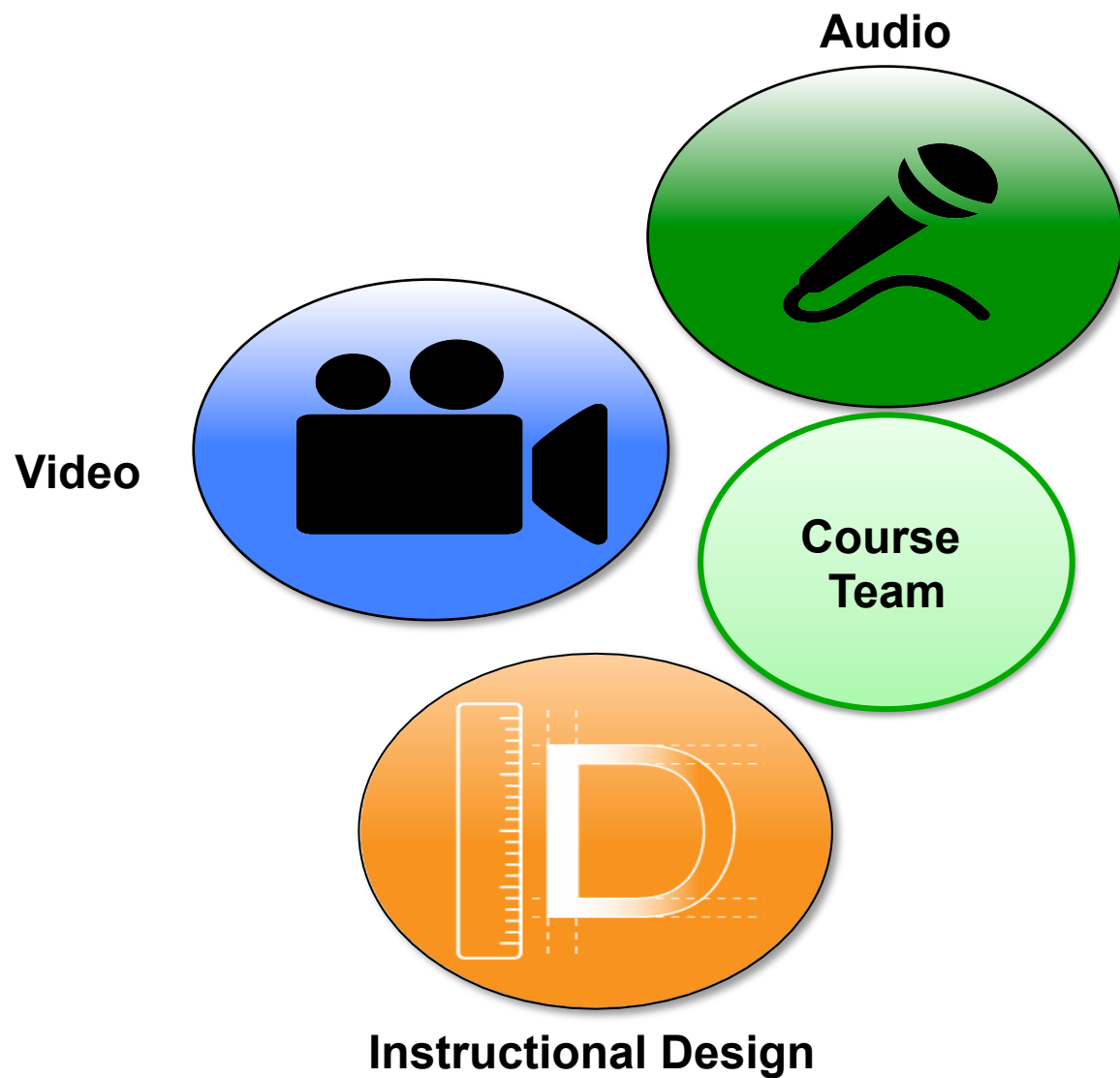



Outline



- Introduction
- **Instructional Design Overview**
- Preparation
- Capturing
- Editing
- Delivery
- Summary



Understanding by Design

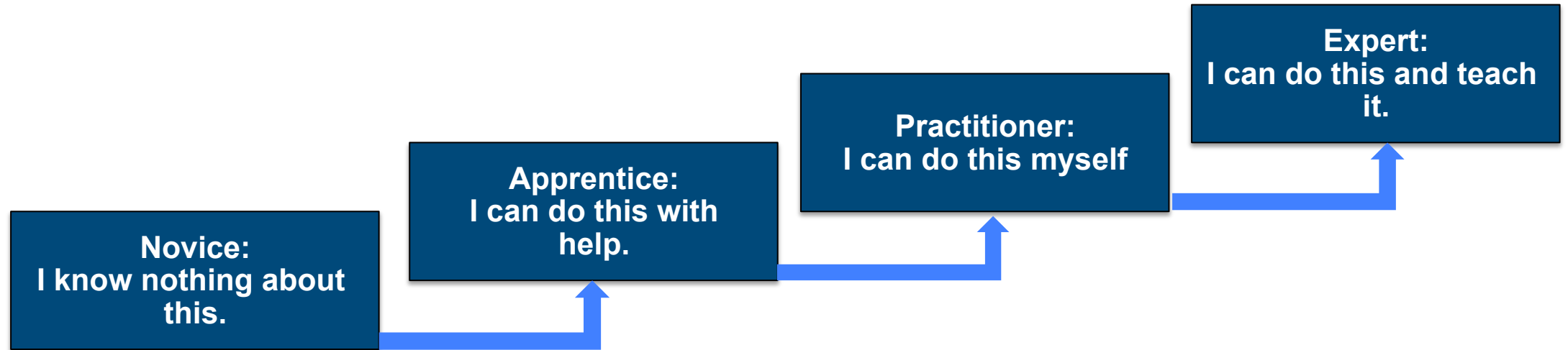



Understanding by Design

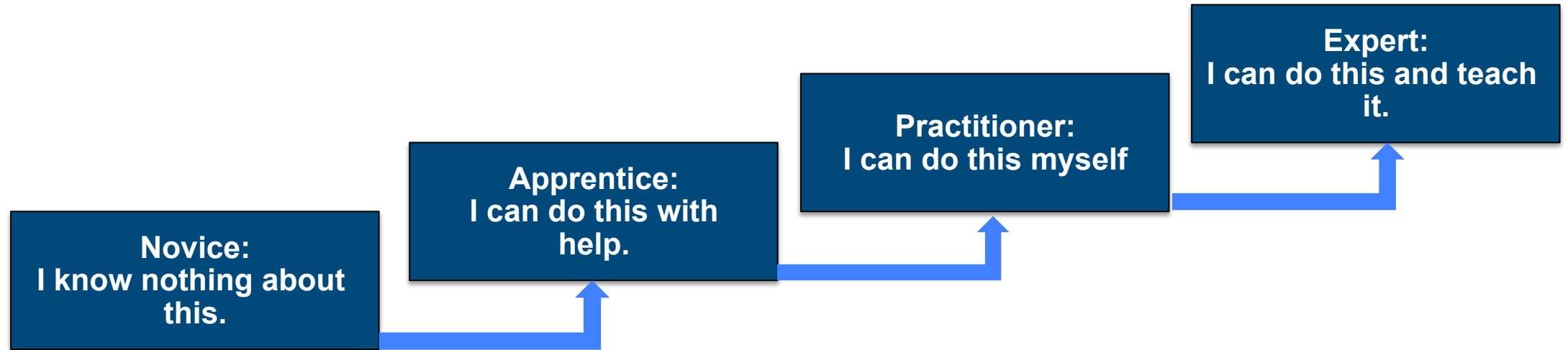

Driving Questions

- What do I want the students to learn in this stage?



Understanding by Design

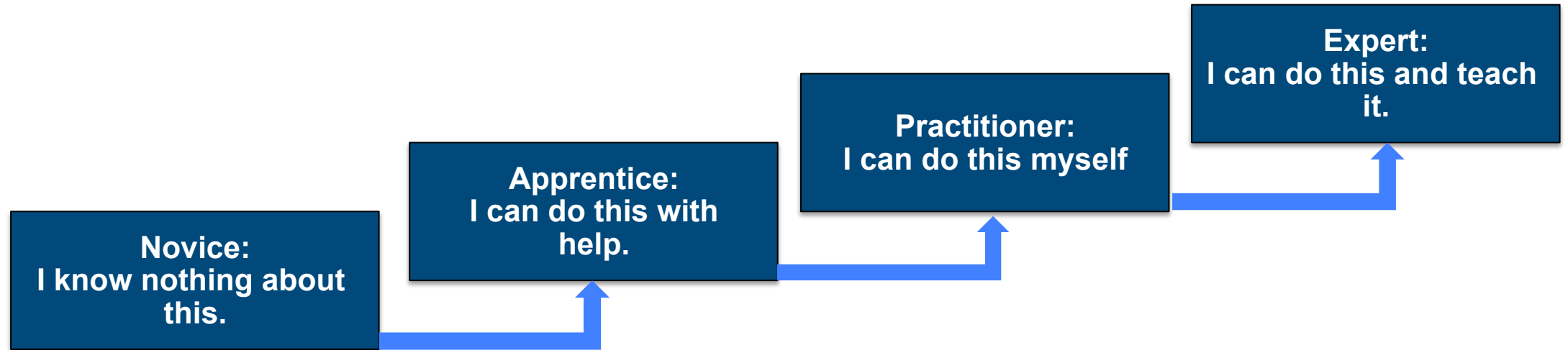

Driving Questions

- What do I want the students to learn in this stage?
➡ This drives the content curation and selection



Understanding by Design

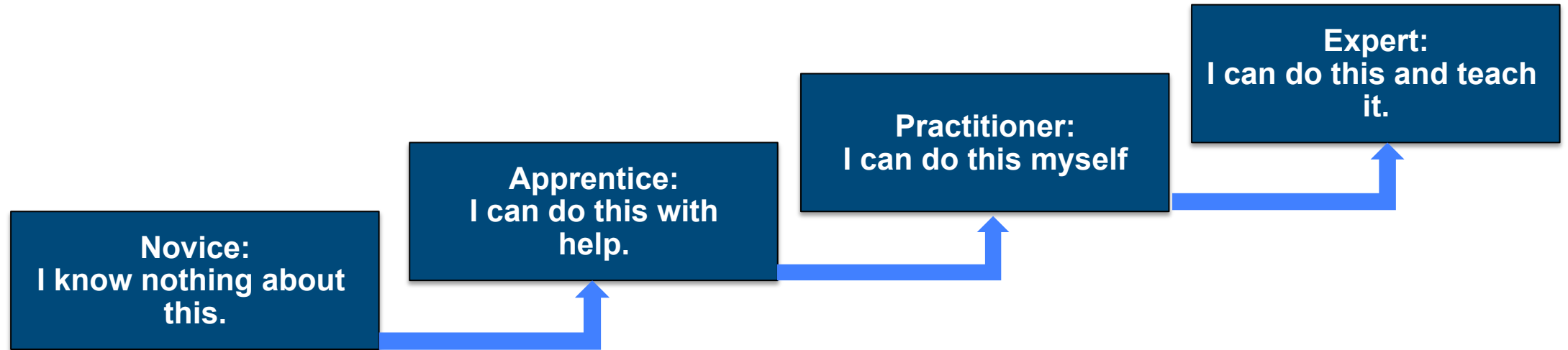

Driving Questions

- **What do you want the students to learn in this stage?**
➡ This drives the content curation and selection
- **How will you know that they have mastered this stage?**



Understanding by Design

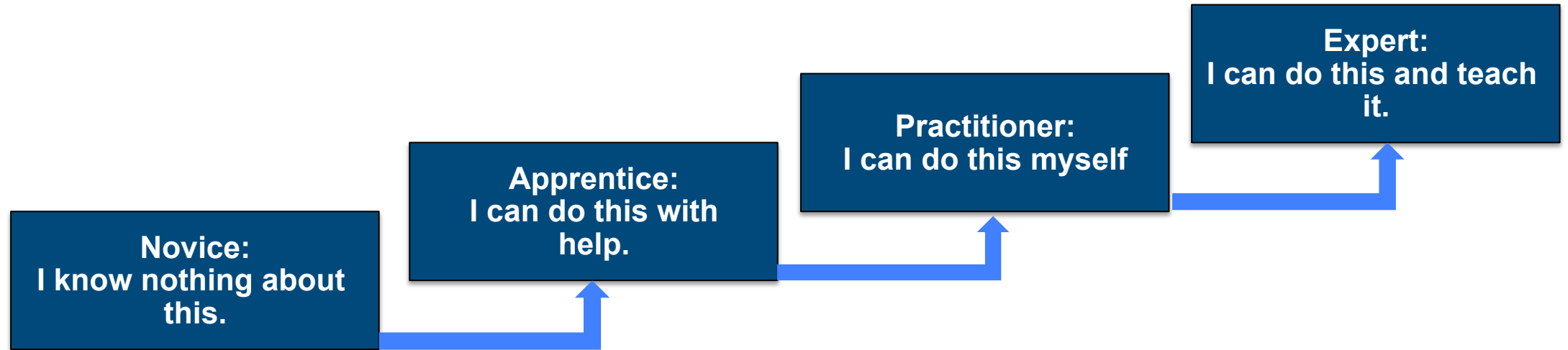

Driving Questions

- **What do I want the students to learn in this stage?**
➡ This drives the content curation and selection
- **How will you know that they have mastered this stage?**
➡ This drives the design of the assessments and activities



Understanding by Design

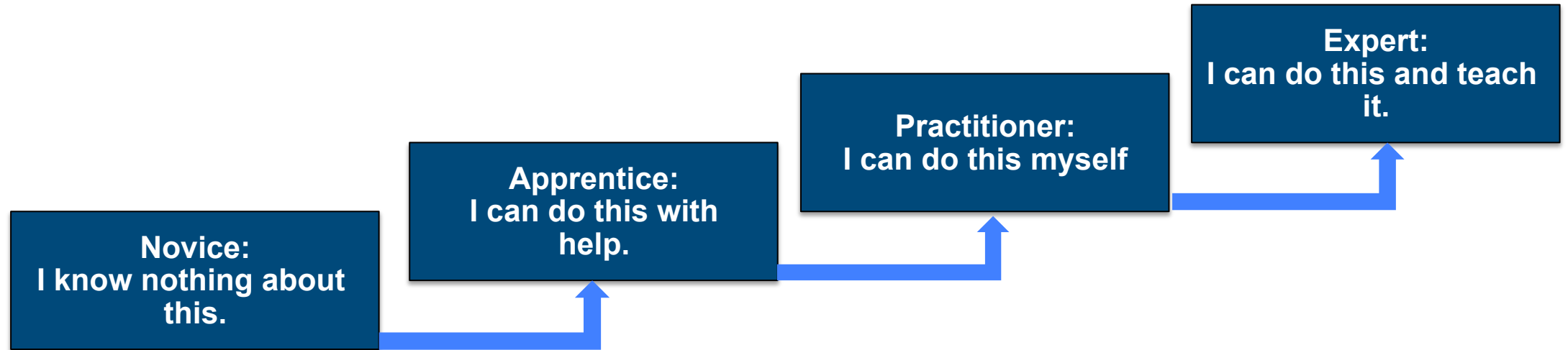

Driving Questions

- What do I want the students to learn in this stage?
➡ This drives the content curation and selection
- How will you know that they have mastered this stage?
➡ This drives the design of the assessments and activities
- What do you need to put in place to support their efforts?



Understanding by Design

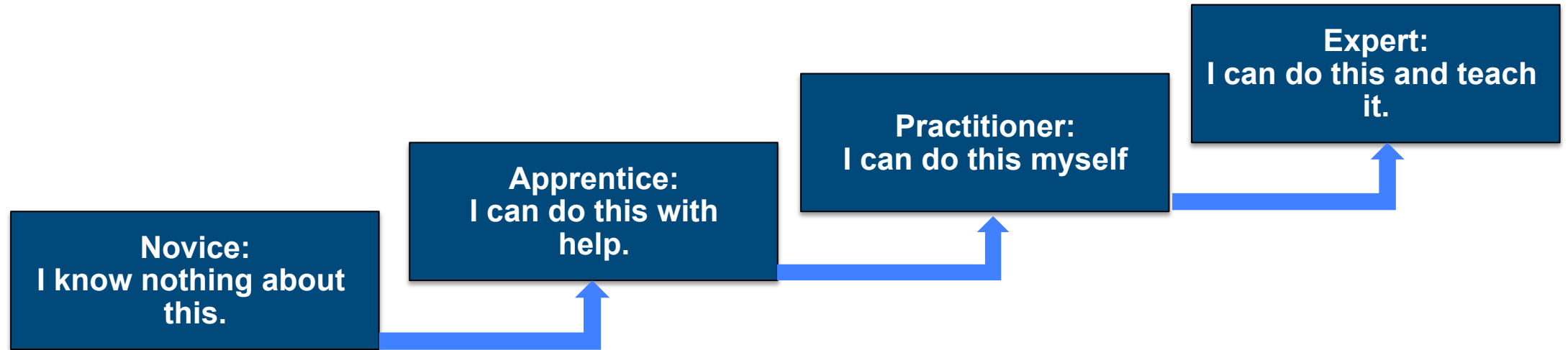

Driving Questions

- **What do I want the students to learn in this stage?**
➡ This drives the content curation and selection
- **How will you know that they have mastered this stage?**
➡ This drives the design of the assessments and activities
- **What do you need to put in place to support their efforts?**
➡ This drives the design of the content delivery



Best Practices for Conversion of Workshops to Online Courses

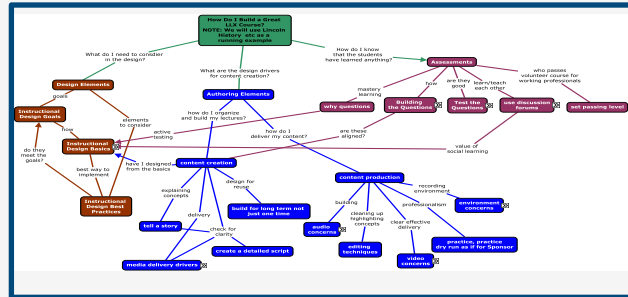

Segmenting Concepts

- Chunking content provides means of scaffolding
- Matches* Cognitive Science understanding of human learning
- Allow for easy assessment and potential remediation

Designing Assessments

- Practice to reinforce learning
- Basic questions confirm understanding e.g. of “Discipline Language”
- Hands-on exercises provide opportunity to learn strategies
- Best exercises use real world applications

Balance Delivery Methods

- Reading has a place
- Delivery modes differ across academic disciplines
- Expert as Guide – shows strategy for analysis, resolution
- Transform lecture – which delivery method is most meaningful



Design Considerations: Video is More Than Class Capture

- **“Video can take the student places they cannot go” James Donald, edX Video Producer**
 - **Television**
 - National Geographic
 - PBS
 - Discovery Channel
 - History Channel
 - News
 - **Webcams**



Design Considerations: Video is More Than Class Capture

- **“Video can take the student places they cannot go” James Donald, edX Video Producer**
 - **Television**
 - National Geographic
 - PBS
 - Discovery Channel
 - History Channel
 - News
 - **Webcams**
- **Video should give the student to a personal tutorial**
 - **Imagine looking over the shoulder of the instructor to see how to**
 - Diagnose and resolve questions or ambiguities
 - Address unknown challenges



Design Considerations: Video is More Than Class Capture

- **“Video can take the student places they cannot go” James Donald, edX Video Producer**
 - **Television**
 - National Geographic
 - PBS
 - Discovery Channel
 - History Channel
 - News
 - **Webcams**
- **Video should give the student to a personal tutorial**
 - **Imagine looking over the shoulder of the instructor to see how to**
 - Diagnose and resolve questions or ambiguities
 - Address unknown challenges
- **Not everything needs to be a video, sometimes there is another medium that is more appropriate to the lesson**



Design Considerations: Segmenting Content via Concept Maps

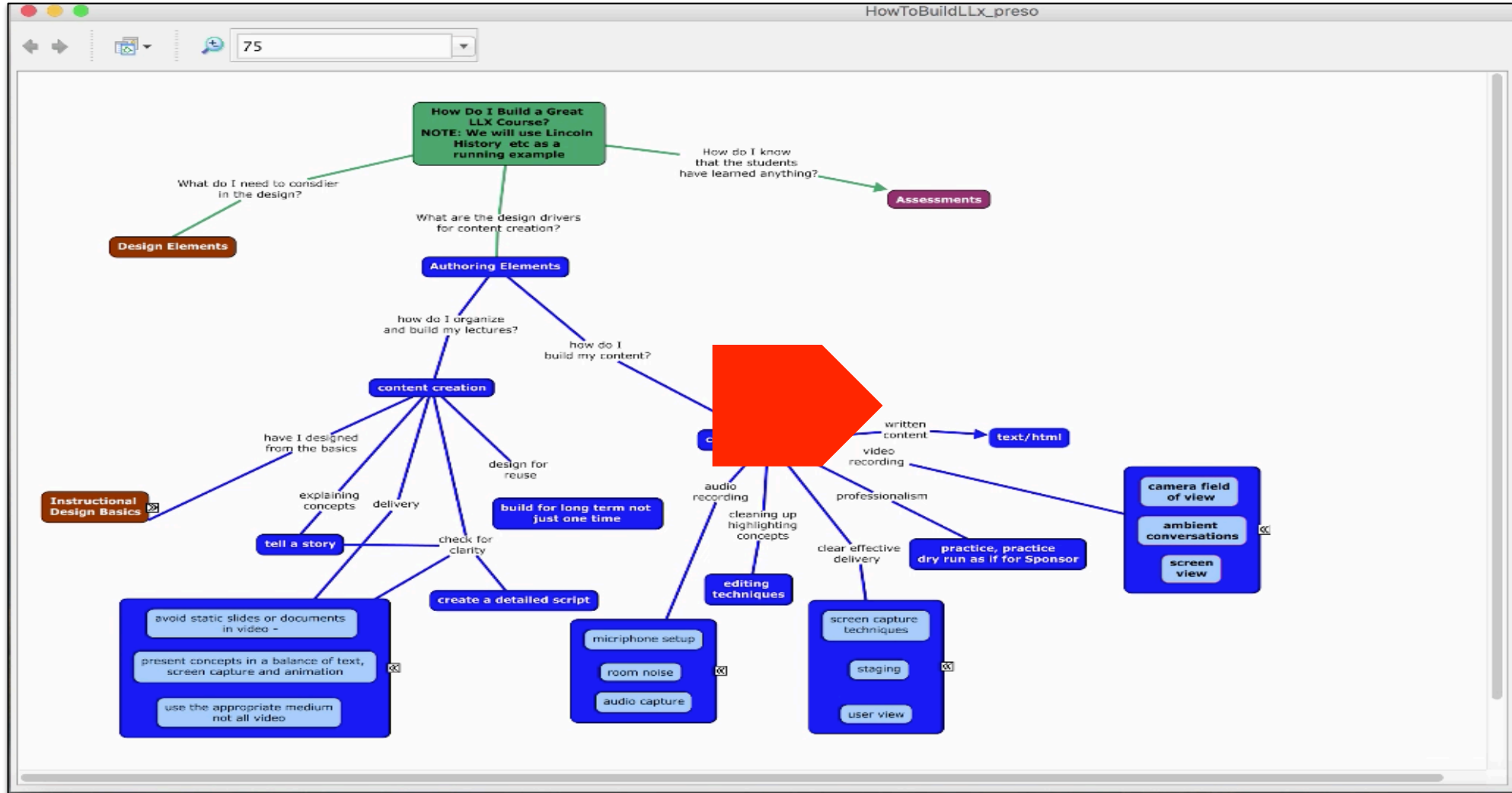



Video Creation Workflow

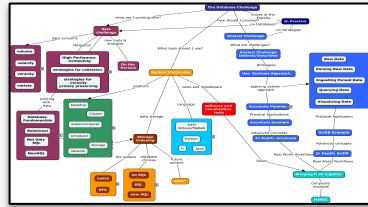

Content Preparation

- Build Out Materials
- Create Complete Script
- Practice Script, Edit, Repeat



Integrate Element into Course



Prepare Room

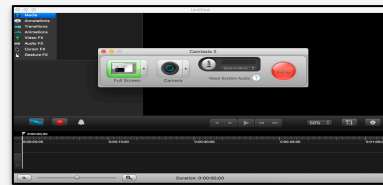
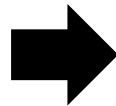

Record

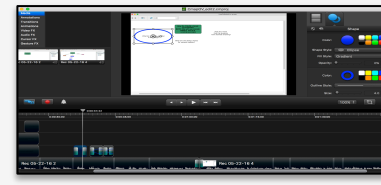
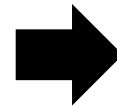

Edit

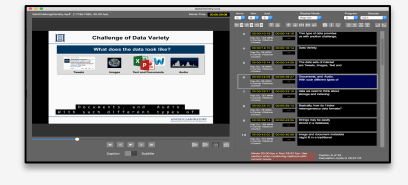
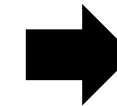

Delivery Prep





Outline



- Introduction
- Instructional Design Overview
- Preparation
- Capturing
- Editing
- Delivery
- Summary



Preparation

- **Select Concept**
 - Small enough to be a single unit?
 - Does it require a series of units?
- **Determine the best methods of delivery**
 - Text
 - Image or diagram
 - Thought exercise to prime for video or text
 - Video
- **Script**
 - Check for content gaps, is there anything missing
 - Confirm that there isn't anything extraneous
 - Practice script – people don't write the in their “speaking voice”
- **Build out your slides for greater control during capture**



Video and Screen Capture Tools for the DIY Producer

Audio



Video



Final Cut Pro X

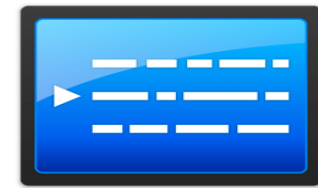

Software



Screen Capture Room Layout



Audio Tools

**Audio-Technica USB
Microphone**



Capture Tools

**Camtasia
(Mac or PC)**



Screen Capture Room Layout



There are no distracting images behind me



Audio Tools

Audio-Technica USB
Microphone



Capture Tools

Camtasia
(Mac or PC)



Screen Capture Room Layout

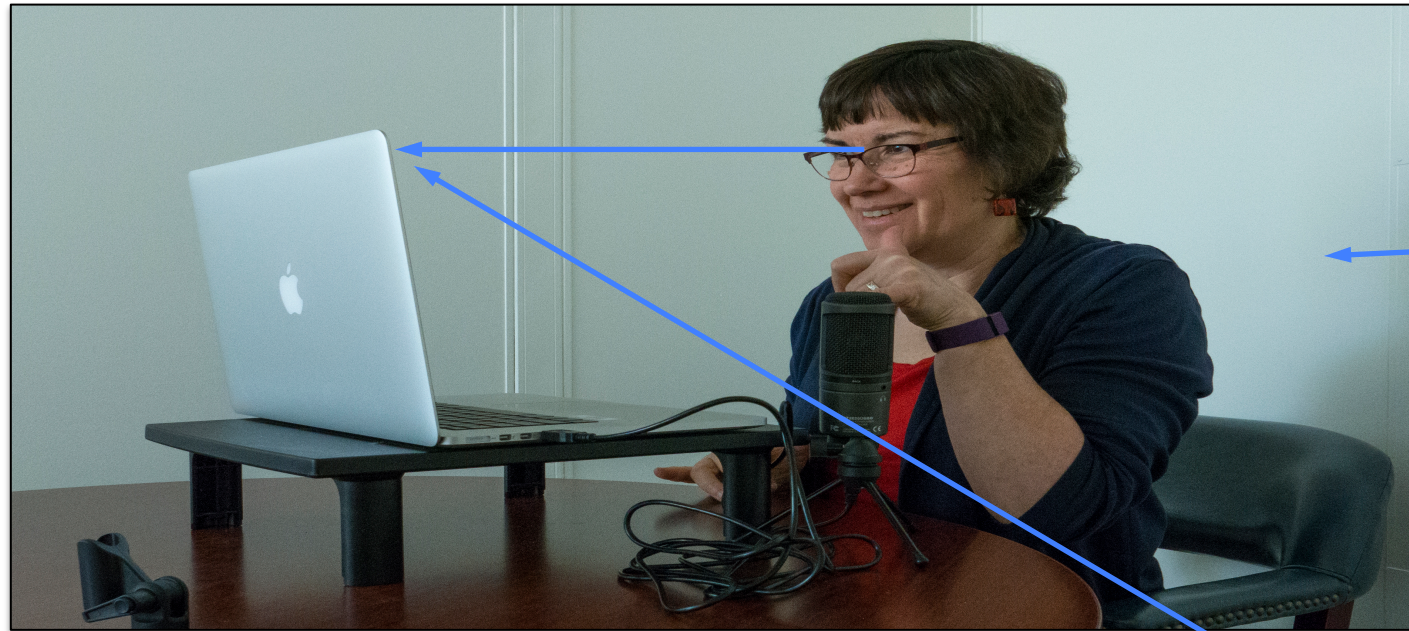

There are no distracting images behind me

Eyes are level with the camera for “In Person” introduction to the unit.



Audio Tools

Audio-Technica USB
Microphone



Capture Tools

Camtasia
(Mac or PC)



Screen Capture Room Layout

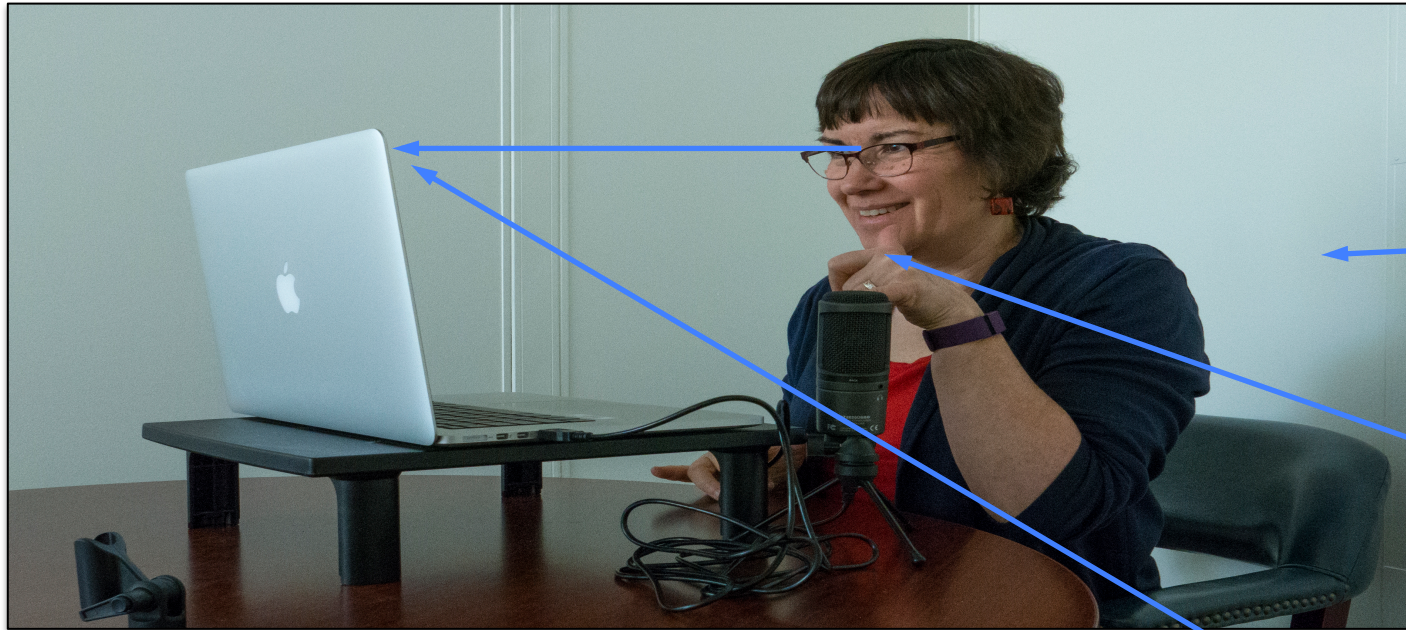

There are no distracting images behind me

Microphone roughly an hand's span from my mouth

Eyes are level with the camera for "In Person" introduction to the unit.



Audio Tools

Audio-Technica USB
Microphone



Capture Tools

Camtasia
(Mac or PC)



Video Capture Room Layout

Video Recording Tools

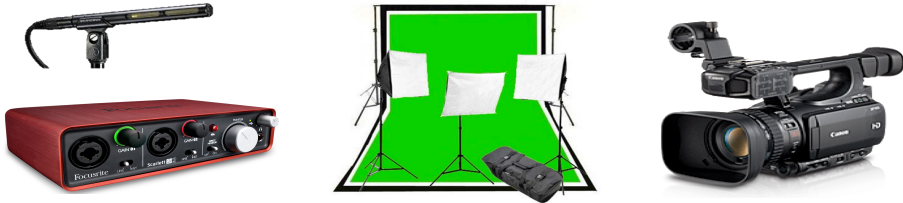

Production Tools



Editing Tools

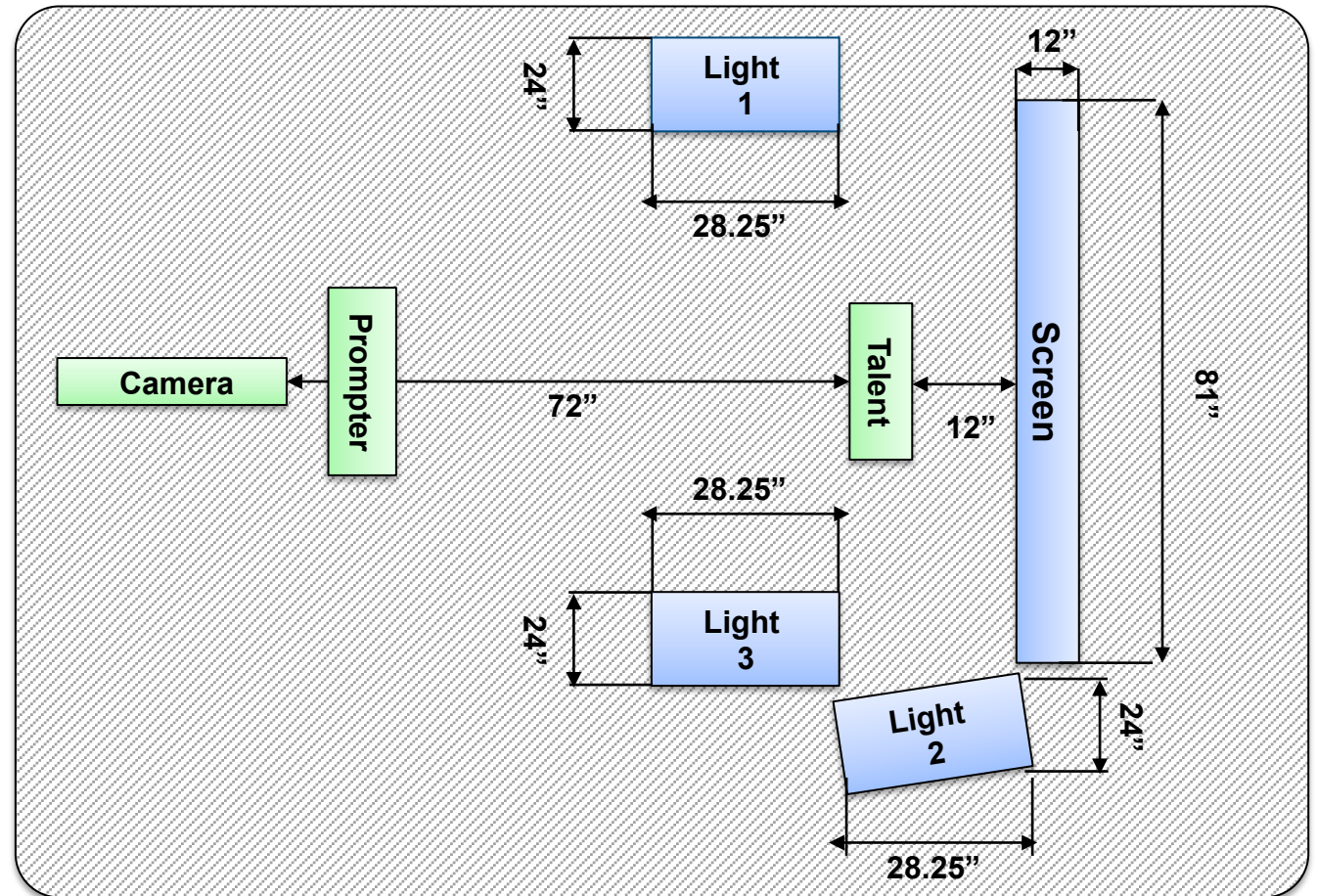



Outline



- Introduction
- Instructional Design Overview
- Preparation
- **Capturing**
- Editing
- Delivery
- Summary



Video Recording and Screen Capture Tips

- **Preparation**
 - **Wear quiet cloths, microphones will pick up rustling**
 - **Wear quiet jewelry or none at all.**
 - **Practice with teleprompter to determine comfortable pace**



Video Recording and Screen Capture Tips

- **Preparation**
 - **Wear quiet cloths, microphones will pick up rustling**
 - **Wear quiet jewelry or none at all.**
 - **Practice with teleprompter to determine comfortable pace**
- **Short videos, short segments**
 - **Less likely to make a mistake**
 - **Easier to retake if there is a mistake**
 - **Can edit in transitions to tie them together**



Video Recording and Screen Capture Tips

- **Preparation**
 - Wear quiet cloths, microphones will pick up rustling
 - Wear quiet jewelry or none at all.
 - Practice with teleprompter to determine comfortable pace
- **Short videos, short segments**
 - Less likely to make a mistake
 - Easier to retake if there is a mistake
 - Can edit in transitions to tie them together
- **Video Sessions**
 - Keep them short
 - More than an hour is exhausting
 - After about an hour the quality of your voice changes
 - Stay hydrated, have snacks, avoid milk products



Video Recording and Screen Capture Tips

- **Listen to the ambient noise of the room**
 - **If it is too loud, e.g. HVAC, find another room**
 - **Find the quietest place in the room to set up**
 - **Place a note on your door, so no one enters and disrupts the session**



Video Recording and Screen Capture Tips

- **Listen to the ambient noise of the room**
 - If it is too loud, e.g. HVAC, find another room
 - Find the quietest place in the room to set up
 - Place a note on your door, so no one enters and disrupts the session
- **Take a test video segment to check the audio**



Video Recording and Screen Capture Tips

- **Listen to the ambient noise of the room**
 - If it is too loud, e.g. HVAC, find another room
 - Find the quietest place in the room to set up
 - Place a note on your door, so no one enters and disrupts the session
- **Take a test video segment to check the audio**
- **Leave space at the beginning of the capture – it allows you to splice videos**



Video Recording and Screen Capture Tips

- **Listen to the ambient noise of the room**
 - If it is too loud, e.g. HVAC, find another room
 - Find the quietest place in the room to set up
 - Place a note on your door, so no one enters and disrupts the session
- **Take a test video segment to check the audio**
- **Leave space at the beginning of the capture – it allows you to splice videos**
- **Correcting Mistakes**
 - **Screen Capture:**
 - Pause capture or simply stop speaking, breathe and say “reset”
 - Starting over only necessary if content being updated
 - Roll the presentation back, reset the screen
 - Start the audio track again
 - **Video generally requires reshooting from the beginning**



Audio Recording Tips



Carotid microphone

- **Audio is usually the most important part of educational videos!**



Audio Recording Tips



Carotid microphone

Sensitivity Back

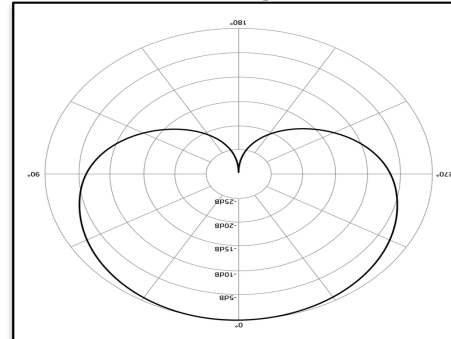

Sensitivity Front

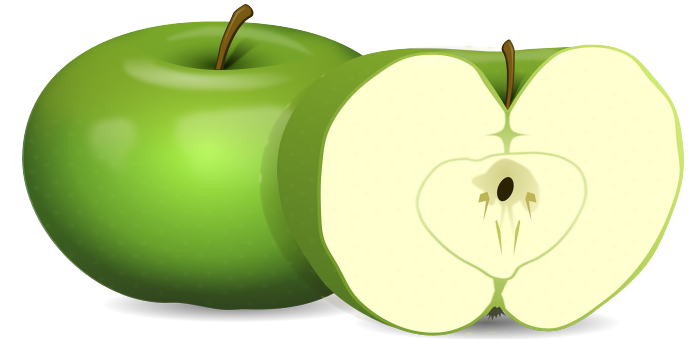

Polar Plot Stand-In
And Voice Preparation

- **Audio is usually the most important part of educational videos!**
- **Most microphones used for voice are carotid:**
 - **Sensitivity envelope is focused toward the front**
 - **Sensitivity decreases on the sides**
 - **Little to no pick-up at the back**



Audio Recording Tips



Carotid microphone

Sensitivity Back

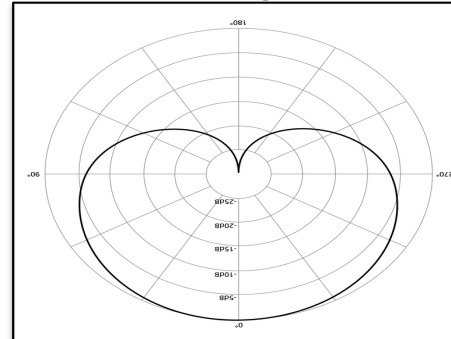

Sensitivity Front

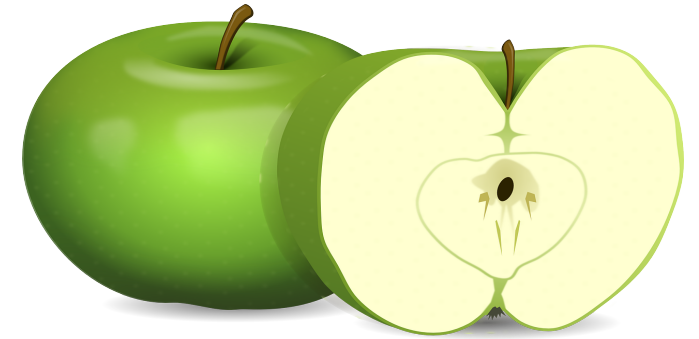

Polar Plot Stand-In
And Voice Preparation

- **Audio is usually the most important part of educational videos!**
- **Most microphones used for voice are carotid:**
 - **Sensitivity envelope is focused toward the front**
 - **Sensitivity decreases on the sides**
 - **Little to no pick-up at the back**
- **Check your microphone to avoid picking up unwanted sound**



Audio Recording Tips



Carotid microphone

Sensitivity Back

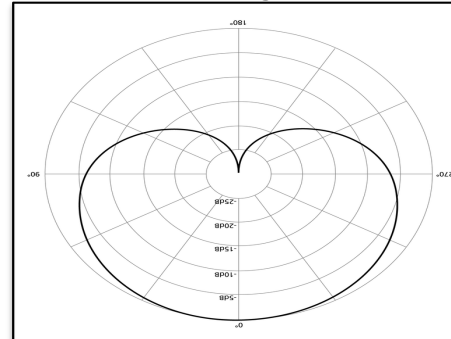

Sensitivity Front

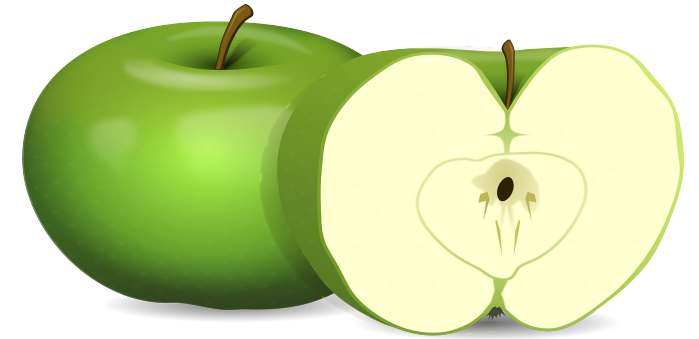

Polar Plot Stand-In
And Voice Preparation

- **Audio is usually the most important part of educational videos!**
- **Most microphones used for voice are carotid:**
 - Sensitivity envelope is focused toward the front
 - Sensitivity decreases on the sides
 - Little to no pick-up at the back
- **Check your microphone to avoid picking up unwanted sound**
- **Prepare your voice:**
 - Stay hydrated
 - Slices of green apple (Granny Smith) help keep mouth moist



Outline

- Introduction
- **Instructional Design Overview**
- Preparation
- Capturing
- Editing
- Deployment
- Summary





Camtasia Screen Capture Example Raw Video

The screenshot displays the Camtasia software interface. The main window shows a screen capture of a presentation slide titled "How Do I Build a Great LLX Course?" with a note: "NOTE: We will see Lincoln History etc as a running example." The interface includes a left sidebar with various editing tools like Media, Annotations, Transitions, Animations, Video FX, Audio FX, Cursor FX, and Gesture FX. Below the sidebar, two video thumbnails are shown, labeled "Rec 05-22-16 2" and "Rec 05-22-16 4", with a red box around them and the text "Captured videos". The bottom section features a timeline with a red box around it and the text "Timeline". The timeline includes a duration of "0:00:00,00" and "0:02:26,16". Red arrows point to "Restarts" and "Space for editing" on the timeline. The overall interface is dark-themed.



Screen Capture: The Importance of empty space



First Attempt

Reset

Corrected Version

**The large empty spaces provide room to edit and clean up audio errors
Pausing and restarting yields consistent vocal sound**



Camtasia Screen Capture Example Edited Video

The screenshot shows the Camtasia software interface. The main preview window displays a slide with a diagram and text. The diagram consists of a blue oval with a central point and lines connecting it to other points. The text on the slide includes: "How Do I Build a Great LLX Course?", "NOTE: We will use Lincoln History etc as a running example", "What do I know that the students have learned anything?", and "What are the design drivers for content creation?". The right sidebar shows the "Shape" settings, including Color, Shape Style (Ellipse), Fill Style (Gradient), Opacity (0%), Outline Style, and Size (4.0). The timeline at the bottom shows two video clips, "Rec 05-22-16 2" and "Rec 05-22-16 4", with red annotations: "Added Highlights", "Removed Resets", and "Transition at start".



Professional Video Editing Tools: Adobe Premier, Final Cut Pro



Final Cut Pro X Interface

- Ideal tools for
 - Video editing
 - Adding effects
- Easy to join multiple clips
- Audio effects
 - Flexible
 - Fine grained
- Adobe supports
 - PC
 - Mac
- Final Cut Pro Mac only



Outline

- Introduction
- Instructional Design Overview
- Preparation
- Capturing
- Editing
- Delivery
- Summary





Delivery Requirements

- **Formats playable by all browsers:**
 - Safari, Chrome and Internet Explorer use mp4
 - Firefox supports webm
 - Converters exist to create the format you need
 - YouTube
 - Movavi
 - VLC (Mac or PC)
- **The ADA* requires captioning for videos**
 - MacCaption – expensive, but quick if you have a script
 - Camtasia – PC version supports voice to text (still immature)
 - YouTube – voice to text capability (still immature)
- **The ADA* requires that text and slides be “readable” by plug-ins for the blind**



Camtasia Captioning (Studio 8 PC Version Only)

The screenshot displays the Camtasia Studio 8 interface with the following components:

- Global settings:** Includes font settings (Arial, size 18) and a checked "Show Captions" option.
- Captions Panel:** A list of timed captions with their corresponding text. A red label "Timed Captions Text" is overlaid on this panel.
- Preview Window:** Shows a video frame with a green callout box containing the text: "How Do I Build a Great LLX Course? NOTE: We will use Lincoln History etc as a running example".
- Timeline:** A horizontal axis at the bottom showing video duration from 00:00:00:00 to 00:01:40:00. A red label "Timeline" is overlaid on this section.
- Caption Track:** A track below the timeline showing individual caption segments with their text, labeled "Caption Track".
- Taskbar:** Shows the Windows taskbar with various application icons and a system tray displaying the time 2:58 PM and date 5/23/2016.



Camtasia Captioning (Studio 8 PC Version Only)

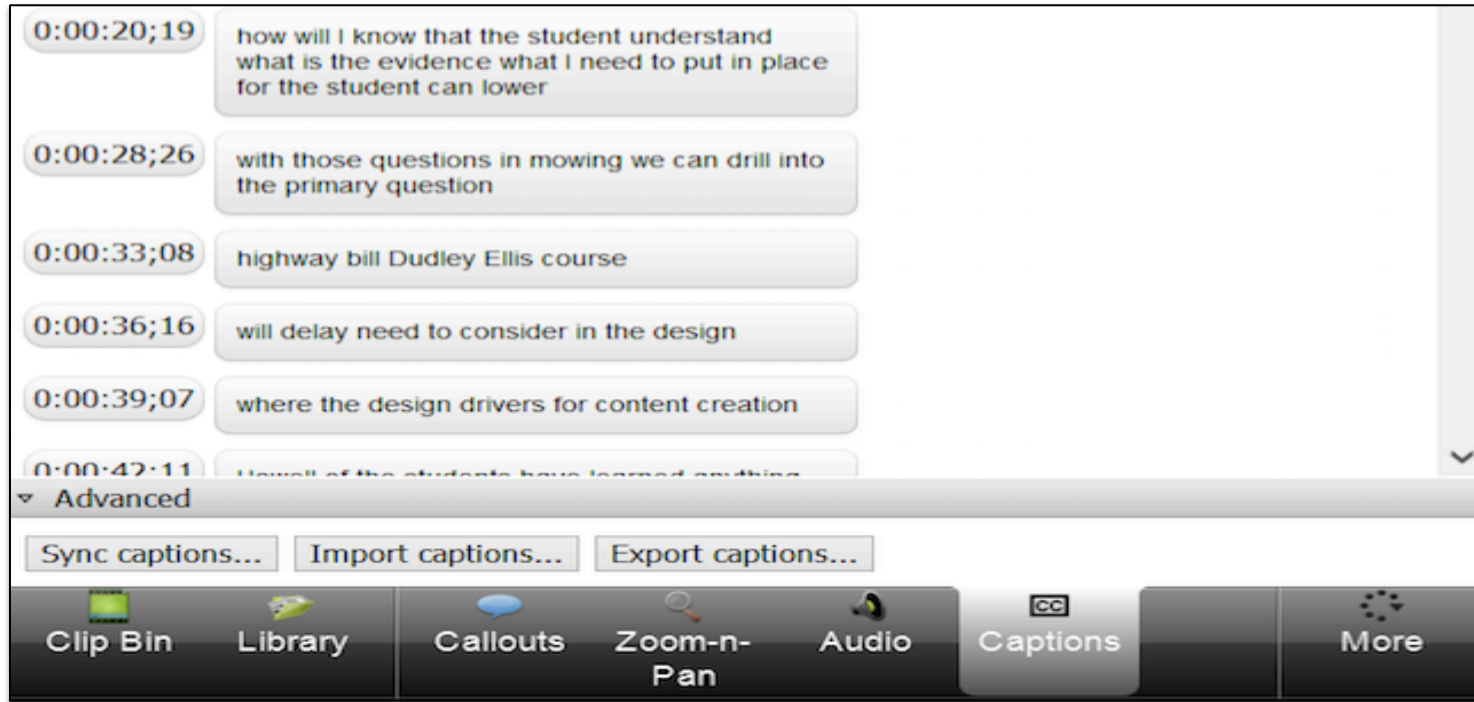

- How will I know that the student
- What do I need to put in place so that the student can learn?
- With those questions in mind we can drill into the primary question on the concept map
- What do I need to consider in the design?
- What are the design drivers for content creation?

- Agreement is fairly good, but still requires significant editing
- Camtasia provides a way to “train” the tool to your voice patterns
- YouTube provides similar accuracy



Outline

- Introduction
- **Instructional Design Overview**
- Preparation
- Capturing
- Editing
- Delivery
- Summary





Screen Capture and Video Editing Software Trade-offs

Name	Primary Function	Learning Curve	Cost*	Comments
Camtasia (Techsmith.com)	Screencast Video editing	Easy	>\$100 (Mac) >\$175 (PC)	Mac or Windows Good Tutorials Provided
Screenflow (Telestream.net)	Screencast	Easy	~\$100	Mac or Windows
Final Cut Pro X (www.apple.com/final-cut-pro)	Video Editing	Moderate to Steep	~\$300	Mac Only Extensive Toolset
Adobe Premier & After Effects (Adobe.com)	Video Editing	Moderate to Steep	~\$150 - \$300	Mac or Windows Extensive Toolset



Audio Recording and Editing Software Trade-offs

Name	Primary Function	Learning Curve	Cost*	Comments
Audacity (AudacityTeam.com)	Audio recording and editing	Easy	Free	Mac, Windows, Linux
Avid Pro Tools (avid.com)	Audio recording and editing	Moderate to Steep	~\$300	Mac Windows with limitations Professional Grade Designed for music
Reaper	Audio recording and editing	Moderate to Steep	~\$60	Professional Grade Designed for music



Video Captioning and Conversion Software Trade-offs

Name	Primary Function	Learning Curve	Cost*	Comments
Movavi (Movavi.com)	Video Conversion	Easy	~\$40	Mac, Windows
YouTube (YouTube.com)	Video Conversion, Captioning and hosting	Easy	Free	Must be able to expose your content to public
VLC (videolan.org)	Video player, Conversion	Easy	Free	YouTube videos on how to convert videos
MacCaption (Telestream.net)	Video Caption	Easy	~\$1000	Simple, efficient captioning requires script
Camtasia (PC only) (Techsmith.com)	Screencast, Editing, Captioning	Easy	~\$150	Speech-to-text requires significant editing. Tool can learn “your voice”



Summary

- **We presented a process for converting traditional learning experiences to online courses**
- **We discussed best practices in online course development**
- **We presented a workflow for creating the video components of an online course and provide tips for**
 - **Preparing the material**
 - **Preparing the recording environment**
 - **Recording a screencast**
 - **Captioning the final video**
- **We presented tables of the trade-offs among the software tools for each stage of the workflow**



Acknowledgements

- **LLx Platform Support**

- William Bergeron
- Michael Houle
- Michael Jones
- Andrew Prout

- **LLx Course Instructors**

- Kenny Alperin
- Patrick Bell
- Vijay Gadepally
- Ken Kolodziej
- Christopher Landry
- Lisa Morelli
- Rasiah Senthurchelvan

- **Lincoln Laboratory Supercomputing Center**

- William Arcand
- David Bestor
- Chansup Byun
- Matthew Hubbell
- Jeremy Kepner
- Anna Klein
- Peter Michaleas
- Albert Reuther
- Antonio Rosa
- Siddharth Samsi
- Charles Yee

Contact: jsm@ll.mit.edu



Backup
